

CAD FILE:

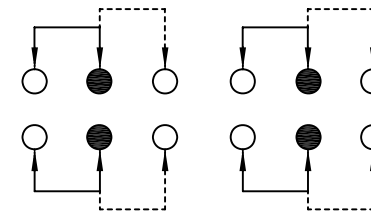

SCHEMATIC (SHORTING)

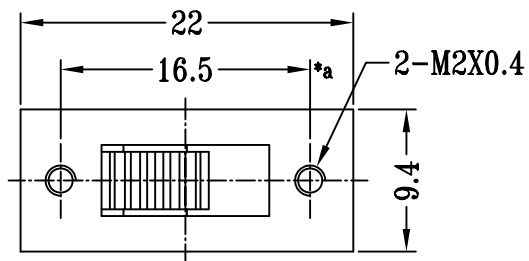
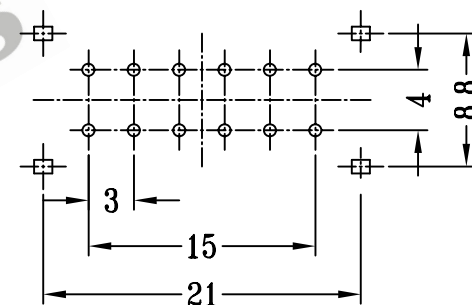
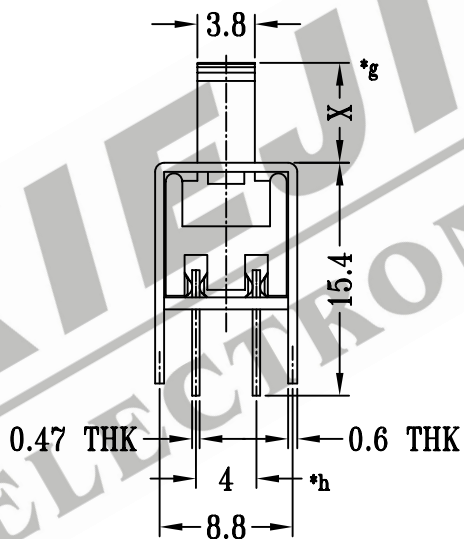
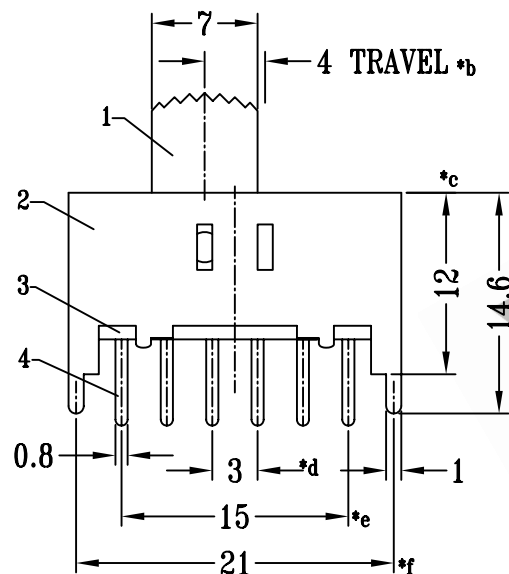

P.C.B LAYOUT

注:带"*"表示关键尺寸(8个)

NO.	PART NAME	MATERIAL	Q'TY	FINISHING	TOLERANCE UNLESS SPECIFIED	SHENZHEN XIEJIA ELECTRONICS CO.,LTD.			
8						ISSUE	DATE	DESCRIPTIONS	APPD.
7	STEEL BALL	STEEL	2	NATURAL	WITHIN: 1.5±0.1mm				
6	SPRING	STEEL WIRE	1	TEMPER	OVER : 1.5±0.2mm				
5	CONTACT CLIP	PBS STRIP	4	Ag PLATED					
4	TERMINAL	BRASS STRIP	12	Ag PLATED OVER Ni PLATED	TITLE : VERTICAL SLIDE SWITCH	UNIT : MM	DRWG NO.: XJ-DR-SS42H12-00		
3	BASE	PHENOLIC RESIN	1	NATURAL	MODEL: SS-42H12	SCALE: 2:1	DWN.	ZHOUYU	2005-11-7
2	FRAME	STEEL STRIP	1	Ni PLATED			CHK'D	FANGYING	2005-11-7
1	KNOB	POM	1	BLACK	ALL MATERIALS MUST BE COMPLIANT TO ROHS		APPD.	KANGXINAN	2005-11-7